

FG-70(L/H/K) FOG Instructions



1 Overview

This document specifies the requirements and methods for the use and maintain of the FG-70 single-axis fiber optic gyroscope.

2 Instruction

2.1 Product working principle,function and range of application

2.1.1 Working principle

This product is an inertial angular rate sensor based on Sagnac effect to measure the angular velocity of rotation of the carrier along the sensitive axis. Using digital closed-loop detection circuit to extract the light velocity difference caused by the external physical angular velocity of the optical fiber ring sensitive, the light-frequency-transmitted light is differential, and the voltage signal of the optical range difference is converted into the signal modulation and demodulation, and the closed-loop feedback and control is realized to achieve the purpose of real-time angular velocity signal detection.

2.1.2 Function

This product consists of optical angular speed sensitive unit and signal detection, which provides single-axis angular increment information and internal temperature Infor mation.

2.1.3 Range of application

Products are mainly used in Photoelectric pod, flight control platforms, inertial measuring and navigation system, optical/photographic instruments/platform stabilization devices and inertial measurement instruments and other application

2.2 Composition

The main components of the product are as follows:

- a) Optical Unit: including SLD light source, fiber ring, integrated optical phase modulator, fiber coupler, photodetector;
- b) PCBA Units: light source drive, signal detection and control;
- c) FOG structure part

2.3 Outline and installation size

Outline (mm) : $70\pm 0.1 \times 70\pm 0.1 \times 30\sim 32\pm 0.1$ (L x W x H) ;

Installation (mm) : $62\pm 0.1 \times 62\pm 0.1$ (L×W) , $\Phi 4.0\text{mm} \times 4$, As shown in Figure 1.

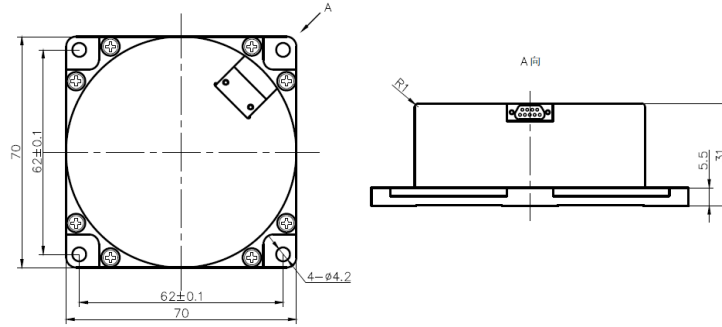

Figure 1 FG-70 fiber-optic gyroscope outline and installation schematic

2.4 Weight

Total weight is 200g~230g±5g.

2.5 Key performance parameters

Main performance parameters of the product are shown in table 1

Table 1 Main performance paramet

Test Item	Unit	FG-70L	FG-70	FG-70H	FG-70K
Size	mm	70×70×30	70×70×31	70×70×31	70×70×32
Start-up time	s	<5	<5	<5	<5
Room temperature (constant temperature) Bias Stability (10s 1σ)	°/h	≤0.3	≤0.1	≤0.05	≤0.03
Full temperature Bias Stability (100s 1σ)	°/h	≤1	≤0.3	≤0.05	≤0.03
Bias repeatability	°/h	≤0.1	≤0.05	≤0.02	≤0.01
Random walk coefficient	°/h ^{1/2}	≤0.01	≤0.01	≤0.005	≤0.003
Scale factor nonlinearity	ppm	≤50	≤20	≤10	≤10
Scale factor repeatability	ppm	≤50	≤20	≤5	≤5
Working temperature	°C	-45+70	-45+70	-45+70	-45+70
Storage temperature	°C	-50~+80	-50~+80	-50~+80	-50~+80
Dynamic range	°/s	±500	±500	±500	±500
Power supply voltage	V	+5	+5	+5	+5
Steady-state power consumption (full temperature)	W	<4	<4	<4	<4

2.6 Mechanical and electrical interface

2.6.1 Power supply

Products are powered by a DC power supply of 5V, and the power supply requirements are shown in Table 2.

Table 2 FG-70 fiber gyroscope power requirements

No.	Description	Specification
1	Power supply accuracy	±5%
2	Power supply ripple (V_{pp})	≤50mV
3	Power Supply Current	>1A

2.6.2 Electrical connector

Connector Part Number is J30JZLN9ZKCA000, detail as table 3.

Table 3 J30JZLN9ZKCA000 FOG connector and test cable definition

No.	Definition	Remark
1	+5V	Power input
2	GND	Ground
3	Reservation	
4	RXD+	Gyro differential signal positive
5	TXD+	Gyro RS422 positive output
6	+5V	Power input
7	GND	Ground
8	RXD-	Gyro differential signal negative
9	TXD-	Gyro RS422 negative output

Note: When connecting or contacting the product, antistatic measures should be taken in accordance with GJB 1649-1993.

2.6.3 Communication Protocol

Communication Interface: Both RXD and TXD are RS422/485 differential signal interfaces, RXD is used to receive differential pulse (or square wave) synchronous strobe signals, and TXD is used for serial data signal output.

Protocol: The strobe signal frequency is no more than 1 kHz. The gyro starts to output the gyro data packet through TXD within 1 μ s after receiving the strobe signal. The transmission baud rate is 460.8 kbps, and the data packet contains 11 bytes. 1 start bit per byte, 8 data bits, 1 stop bit, no parity bit.

The angular increment information is the angular increment value of the gyro in the time between the two strobe signals. The angular increment cumulative value over a period of time divided by the interval time is the average angular velocity of the gyro during this period.

The data packet format is as follows:

Table 4 Gyro Packet Format

No.	Content
1	99 (Hex)
2	66 (Hex)
3	Status word, normal value is FF (Hex)
4	Gyro angle increment 1, LSB
5	Gyro angle increment 2
6	Gyro angle increment 3
7	Gyro angle increment 4, MSB
8	Temperature data, LSB
9	Temperature data, MSB
10	Frame number, plus one for each send, loop count
11	Checksum, the cumulative sum of bytes from 3 to 10.

The status word has the following meaning:

Table 5 Gyro status word data format

bit7	bit6	bit5	bit4	bit3	bit2	bit1	bit0
Reservation	Reservation	Reservation	Circuit control state	Reservation	Reservation	Reservation	Optical status

The "reserved" bit is often 1;

When the "circuit control state" bit is 1, it means that the gyro circuit control state is normal, and when it is 0, it means that the control state is abnormal.

When the "optical state" bit is 1, the gyro optical path works normally, and when it is 0, the gyro optical state is abnormal.

If any of the above two status bits is always 0 during the use of the gyro and the gyro data is abnormal, the gyro should be reworked.